

Prefabrication SECcon - Connection Accessories



Features

- Easy installation and commissioning of sensor cable SEC-LSC-15-XX and connection cable SEC-LSC-15-CC using connectors
- Installation of prefabricated sensor cable SEC-LSC-15-XX without special tooling
- Connectors of prefabricated sensor cable SEC-LSC-15-XX reinforced with shrink-on sleeves
- Connection cables can be fitted on-site without special tooling
- Reverse polarity protection via mechanically coded connectors
- Easy exchange of mechanically damaged components
- Standardisation for periodical infrastructures
- Cost reduction via standardised installation, commissioning, and checks
- Simplified maintenance
- SEC-LSC-15-CON-1 comprises sensor cable SEC-LSC-15-XX prefabrication, including male connector with protection cap and end device
- SEC-LSC-15-CON-2 comprises sensor cable SEC-LSC-15-XX prefabrication, including male and female connectors with protection caps
- Sensor cable lengths must be ordered separately according to customer specification

General Data Connector

- | | |
|------------------------|--|
| • Case material: | Polyamide, halogen-free |
| • Ingress protection: | IP 66 |
| • Connection type: | Spring terminal |
| • Number of terminals: | 3 |
| • Strain relief: | Yes |
| • Latch mechanism: | Yes |
| • Temperature range: | -40 °C ... +100 °C |
| • Contact material: | CuZn |
| • Seal: | NBR |
| • Storage Conditions: | 0 °C ... +60 °C, 30% ... 70% relative humidity, non condensing, prevention against shock, vibration, dust, electrostatic discharge ESD, UV light |

Ordering Information

- Prefabrication SEC-LSC-15-CON-1
Sensor cable SEC-LSC-15-XX prefabrication with 3-pin male connector and end cap
- Prefabrication SEC-LSC-15-CON-2
Sensor cable SEC-LSC-15-XX prefabrication with 3-pin male and female connector
- Sensor Cable SEC-LSC-15-XX
Sensor spacing, sheath material, and length according to customer specification, see data sheet 60V040 for article numbers
- Connector SEC-LSC-15-CON-CS
Female, 3-pin, to couple connection cable SEC-LSC-15-CC with prefabricated sensor cable SEC-LSC-15-CON-1 or SEC-LSC-15-CON-2
- Connector SEC-LSC-15-CON-CP
Male, 3-pin, to couple connection cable SEC-LSC-15-CC with prefabricated sensor cable SEC-LSC-15-CON-2

Tested According to

- Combustion behaviour: UL 94 V-2
- Function element: EN 54-22, approved by VdS Schadenverhütung GmbH, VdS no. G 221004, Environmental class III, Response classes A1N, A2N, BN, CN, A1I, A2I, BI, CI

Application Examples

- Standard variant with pre-assembly SEC-LSC-15-CON-1, per cable port I / II possible

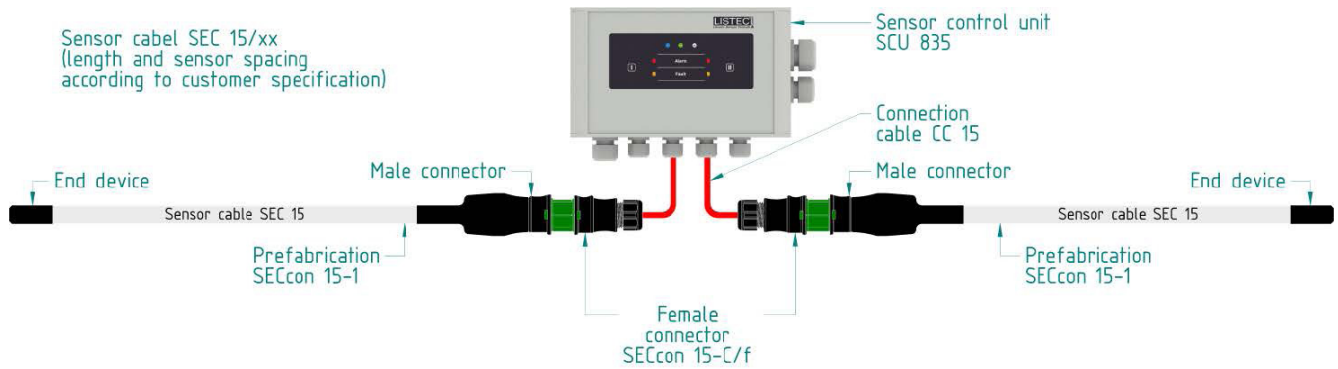

- Variant with pre-assembly SEC-LSC-15-CON-2 and extension with SEC-LSC-15-CON-1, per cable connection I / II possible
- The extensions can consist of several sections, maximum cable length per cable port 350 m, including connection cable SEC-LSC-15-CC

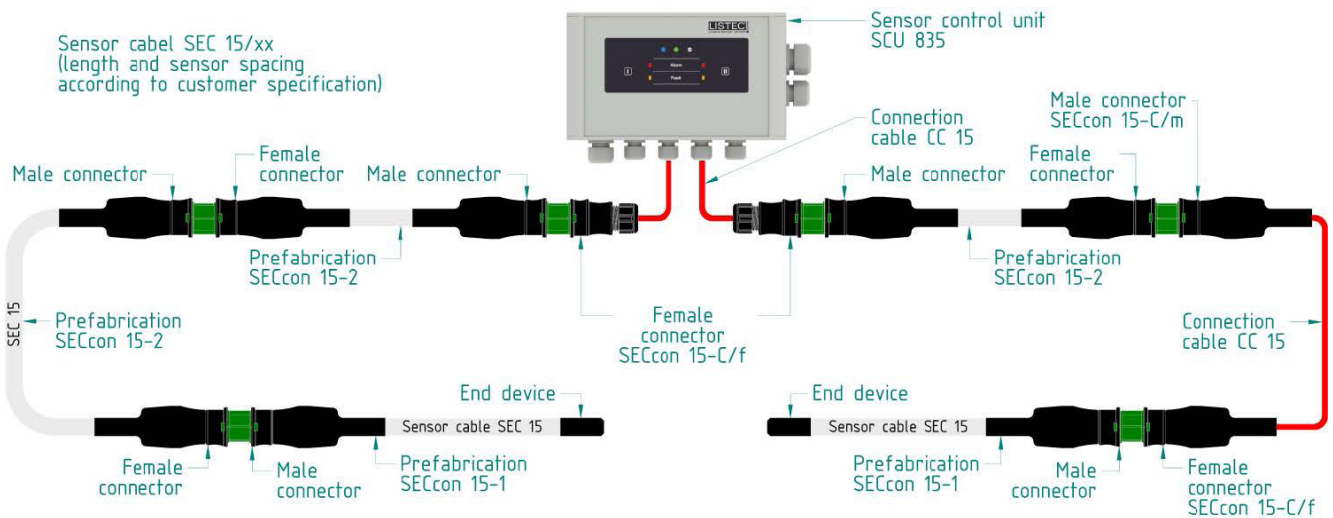

Dimensions

- SEC-LSC-15-CON-CS

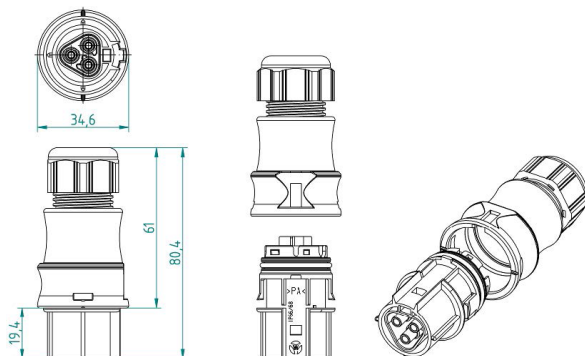

- SEC-LSC-15-CON-CP

